

Anschlussflansche

Typenübersicht Range of types

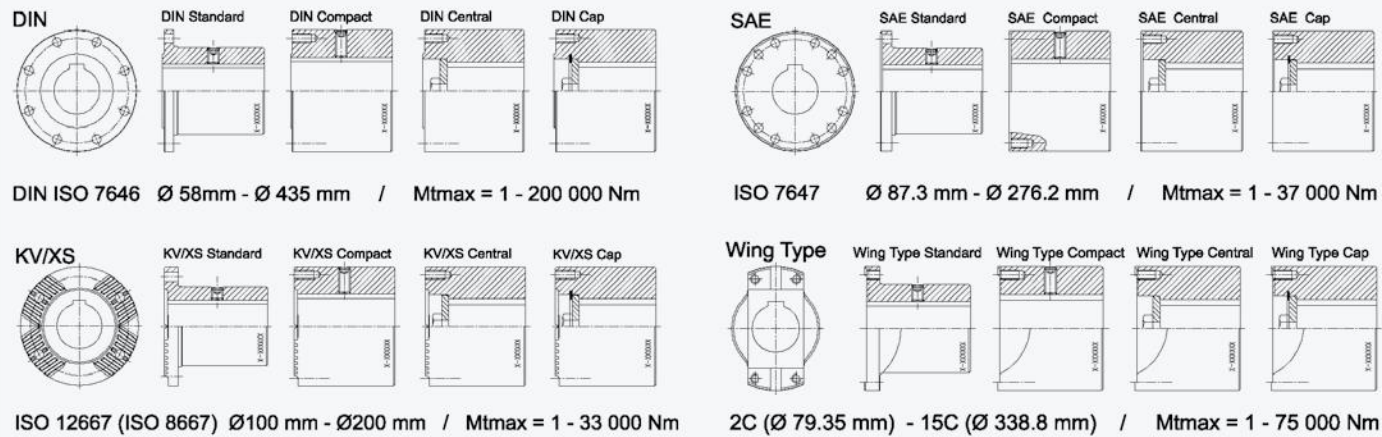

Maßliste Nabe mit Passfeder List of dimensions sleeve with key

DIN 6885

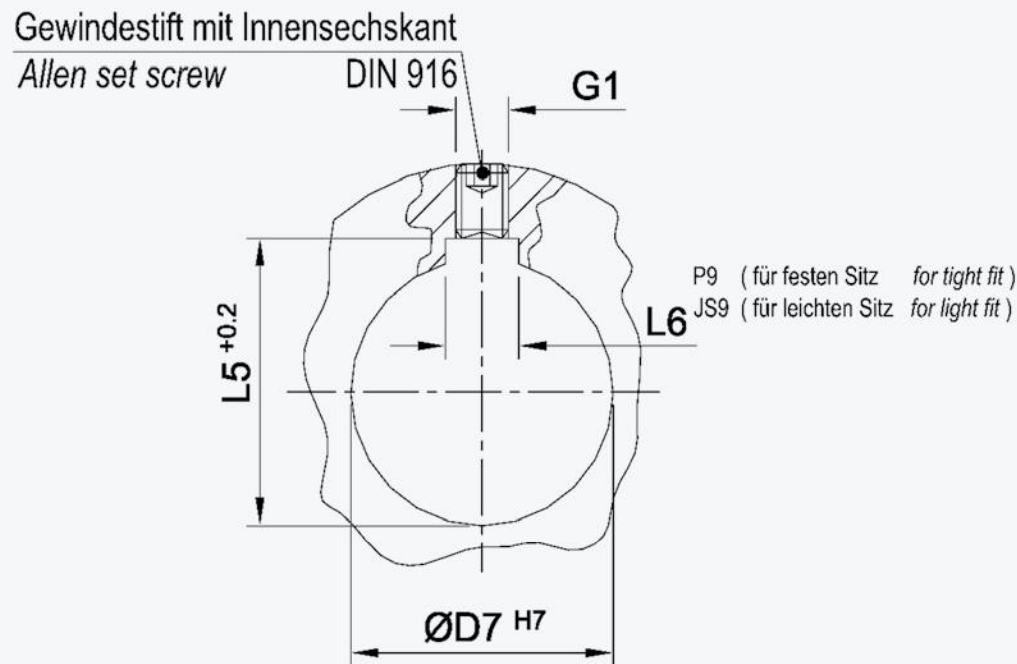

Nutenpassung wahlweise in P9 oder JS9 Passung Nabenbohrung standardmäßig mit H7 Passung. Auf Wunsch jede andere Passung.

Bei fehlender Angaben über die Länge des Wellenstumpfes gilt nach den Regeln der Technik für die richtige Länge L1 des Anschlussflansches und unseren Erfahrungen: **L1 = 1,55 x ØD7**. Wobei das Ergebnis dann auf eine Standard Zahl abgerundet wird (...0,2,4,5,6,8).

Bei Anschlussflansche der Version B mit relativ großer Nabe kann Maß G eventuell entsprechend kleiner angelegt sein.

Key way fit optional with P9 or JS9. Sleeve hole standard fit H7. All other type of fits on request.

If the length of the shaft is not specified following formula is necessary according the state of art and our know how for the length of L1: **L1 = 1.55 x ØD7**. The result have to be rounded down to a standard number (...0,2,4,5,6,8).

For companion flange version B with a relative big sleeve, the size G eventually change to one of the smaller size.

Companion flanges

Maßliste Nabe mit Passfeder List of dimensions sleeve with key

DIN 6885

Ø10-Ø39				Ø40-Ø69				Ø70-Ø99				Ø100-148				Ø150-198			
D7	L6	L5	G1	D7	L6	L5	G1	D7	L6	L5	G1	D7	L6	L5	G1	D7	L6	L5	G1
10	3	11,4	M3	40	12	43,3	M10	70	20	74,9	M18	100	28	106,4	M24	150	36	158,4	M24
11	4	12,8	M3	41	12	44,3	M10	71	20	75,9	M18	102	28	108,4	M24	152	40	161,4	M24
12	4	13,8	M3	42	12	45,3	M10	72	20	76,9	M18	104	28	110,4	M24	154	40	163,4	M24
13	5	15,3	M4	43	12	46,3	M10	73	20	77,9	M18	105	28	111,4	M24	155	40	164,4	M24
14	5	16,3	M4	44	12	47,3	M10	74	20	78,9	M18	106	28	112,4	M24	156	40	165,4	M24
15	5	17,3	M4	45	14	48,8	M12	75	20	79,9	M18	108	28	114,4	M24	158	40	167,4	M24
16	5	18,3	M4	46	14	49,8	M12	76	22	81,4	M20	110	28	116,4	M24	160	40	169,4	M24
17	5	19,3	M4	47	14	50,8	M12	77	22	82,4	M20	112	32	119,4	M24	162	40	171,4	M24
18	6	20,8	M5	48	14	51,8	M12	78	22	83,4	M20	114	32	121,4	M24	164	40	173,4	M24
19	6	21,8	M5	49	14	52,8	M12	79	22	84,4	M20	115	32	122,4	M24	165	40	174,4	M24
20	6	22,8	M5	50	14	53,8	M12	80	22	85,4	M20	116	32	123,4	M24	166	40	175,4	M24
21	6	23,8	M5	51	16	55,3	M14	81	22	86,4	M20	118	32	125,4	M24	168	40	177,4	M24
22	6	24,8	M5	52	16	56,3	M14	82	22	87,4	M20	120	32	127,4	M24	170	40	179,4	M24
23	8	26,3	M6	53	16	57,3	M14	83	22	88,4	M20	122	32	129,4	M24	172	45	182,4	M24
24	8	27,3	M6	54	16	58,3	M14	84	22	89,4	M20	124	32	131,4	M24	174	45	184,4	M24
25	8	28,3	M6	55	16	59,3	M14	85	22	90,4	M20	125	32	132,4	M24	175	45	185,4	M24
26	8	29,3	M6	56	16	60,3	M14	86	25	91,4	M24	126	32	133,4	M24	176	45	186,4	M24
27	8	30,3	M6	57	16	61,3	M14	87	25	92,4	M24	128	32	135,4	M24	178	45	188,4	M24
28	8	31,3	M6	58	16	62,3	M14	88	25	93,4	M24	130	32	137,4	M24	180	45	190,4	M24
29	8	32,3	M6	59	18	63,4	M16	89	25	94,4	M24	132	36	140,4	M24	182	45	192,4	M24
30	8	33,3	M6	60	18	64,4	M16	90	25	95,4	M24	134	36	142,4	M24	184	45	194,4	M24
31	10	34,3	M8	61	18	65,4	M16	91	25	96,4	M24	135	36	143,4	M24	185	45	195,4	M24
32	10	35,3	M8	62	18	66,4	M16	92	25	97,4	M24	136	36	144,4	M24	186	45	196,4	M24
33	10	36,3	M8	63	18	67,4	M16	93	25	98,4	M24	138	36	146,4	M24	188	45	198,4	M24
34	10	37,3	M8	64	18	68,4	M16	94	25	99,4	M24	140	36	148,4	M24	190	45	200,4	M24
35	10	38,3	M8	65	18	69,4	M16	95	25	100,4	M24	142	36	150,4	M24	192	45	202,4	M24
36	10	39,3	M8	66	20	70,9	M18	96	28	102,4	M24	144	36	152,4	M24	194	45	204,4	M24
37	10	40,3	M8	67	20	71,9	M18	97	28	103,4	M24	145	36	153,4	M24	195	45	205,4	M24
38	10	41,3	M8	68	20	72,9	M18	98	28	104,4	M24	146	36	154,4	M24	196	45	206,4	M24
39	12	42,3	M10	69	20	73,9	M18	99	28	105,4	M24	148	36	156,4	M24	198	45	208,4	M24

Ø200-Ø238 Ø240-Ø278 Ø280-Ø318 Ø320-Ø358 Ø360-Ø398

Ø200-Ø238				Ø240-Ø278				Ø280-Ø318				Ø320-Ø358				Ø360-Ø398			
D7	L6	L5	G1	D7	L6	L5	G1	D7	L6	L5	G1	D7	L6	L5	G1	D7	L6	L5	G1
200	45	210.4	M24	240	56	252.4	M30	280	63	292.4	M40	320	70	334.4	M50	360	80	375.4	M60
202	50	213.4	M24	242	56	254.4	M30	282	63	294.4	M40	322	70	336.4	M50	362	80	377.4	M60
204	50	215.4	M24	244	56	256.4	M30	284	63	296.4	M40	324	70	338.4	M50	364	80	379.4	M60
205	50	216.4	M24	245	56	257.4	M30	285	63	297.4	M40	325	70	339.4	M50	365	80	380.4	M60
206	50	217.4	M24	246	56	258.4	M30	286	63	298.4	M40	326	70	340.4	M50	366	80	381.4	M60
208	50	219.4	M24	248	56	250.4	M30	288	63	300.4	M40	328	70	342.4	M50	368	80	383.4	M60
210	50	221.4	M24	250	56	262.4	M30	290	63	302.4	M40	330	70	344.4	M50	370	80	385.4	M60
212	50	223.4	M24	252	56	264.4	M30	292	70	306.4	M50	332	80	347.4	M60	372	80	387.4	M60
214	50	225.4	M24	254	56	266.4	M30	294	70	308.4	M50	334	80	349.4	M60	374	80	389.4	M60
215	50	226.4	M24	255	56	267.4	M30	295	70	309.4	M50	335	80	350.4	M60	375	80	390.4	M60
216	50	227.4	M24	256	56	268.4	M30	296	70	310.4	M50	336	80	351.4	M60	376	80	391.4	M60
218	50	229.4	M24	258	56	260.4	M30	298	70	312.4	M50	338	80	353.4	M60	378	80	393.4	M60
220	50	231.4	M24	260	56	272.4	M30	300	70	314.4	M50	340	80	355.4	M60	380	80	395.4	M60
222	50	233.4	M24	262	63	274.4	M40	302	70	316.4	M50	342	80	357.4	M60	382	90	399.4	M70
224	50	235.4	M24	264	63	276.4	M40	304	70	318.4	M50	344	80	359.4	M60	384	90	401.4	M70
225	50	236.4	M24	265	63	277.4	M40	305	70	319.4	M50	345	80	360.4	M60	385	90	402.4	M70
226	50	237.4	M24	266	63	268.4	M40	306	70	320.4	M50	346	80	361.4	M60	386	90	403.4	M70
228	50	239.4	M24	268	63	270.4	M40	308	70	322.4	M50	348	80	363.4	M60	388	90	405.4	M70
230	50	241.4	M24	270	63	282.4	M40	310	70	324.4	M50	350	80	365.4	M60	390	90	407.4	M70
232	56	244.4	M30	272	63	284.4	M40	312	70	326.4	M50	352	80	367.4	M60	392	90	409.4	M70
234	56	246.4	M30	274	63	286.4	M40	314	70	328.4	M50	354	80	369.4	M60	394	90	411.4	M70
235	56	247.4	M30	275	63	287.4	M40	315	70	329.4	M50	355	80	370.4	M60	395	90	412.4	M70
236	56	248.4	M30	276	63	288.4	M40	316	70	330.4	M50	356	80	371.4	M60	396	90	413.4	M70
238	56	240.4	M30	278	63	280.4	M40	318	70	332.4	M50	358	80	373.4	M60	398	90	415.4	M70

Anschlussflansche

Companion flanges

DIN Standard Version A

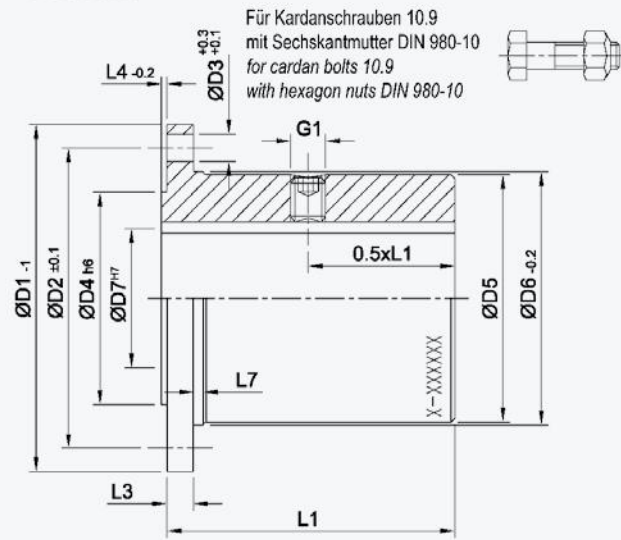

Version B

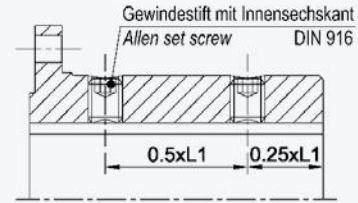

XXXXXX-X
ID Markierung einschließlich aller Kunden ID Daten
ID marking including all customer data

Material: C45

Alle Anschlussflansche einschließlich Gewindestifte
All companion flanges including Allen key screws

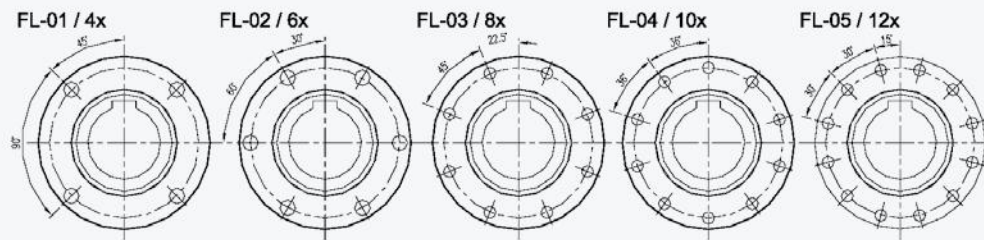

* = meist gebrauchte Länge L1 most used length L1
*** = Baugröße size 114: M10x1x35mm

** = Details Nabe + G1 siehe Seite 44-45 details sleeve + G1 see page 44-45

ØD1 mm	L1 mm	L1* mm	ØD7** mm	ØD2 mm	ØD4 mm	L3 mm	L4 mm	L7 mm	ØD5 mm	ØD6 mm	Ver sion	ØD3 mm	Flansch flange	Schrauben bolts				
														Maß size	Mt Nm			
58	20-50	30	10-22	47	30	4	1.4	3	38	38.8	A	Ø5	FL-01 (4)	M5x15	9			
		30	23-24											B				
65	20-60	40	10-22	52	35	5	1.6	3	40	41.8	A	Ø6	FL-01 (4)	M6x20	14			
		40	23-26											B				
75	20-70	42	10-30	62	42	6	1.9	3	50	51.8	A	Ø6	FL-02 (6)	M6x20	14			
		48	31-34											B				
90	25-75	50	10-38	74.5	47	8	2.3	3	59	61.2	A	Ø8	FL-01 (4)	M8x1x25	36			
		55	39-44											B				
100	25-90	62	20-42	84	57	8	2.3	3	69	70.7	A	Ø8	FL-02 (6)	M8x1x25	36			
		62	43-50											B				
120	25-110	70	26-50	101.5	75	10	2.3	5	82	84.1	A	Ø8	FL-03 (8)	M8x1x30	36			
		85	51-60											B	M10x1x30***	70		
150	35-150	100	41-65	130	90	12	2.8	5	108	110.6	A	Ø10	FL-03 (8)	M10x1x35	70			
		115	66-75											B	Ø12	FL-04 (10)	M12x1.5x40	120
															Ø14	FL-05 (12)	M14x1.5x45	190
180	50-180	120	41-90	155.5	110	14	2.8	5	128	131	B	Ø12	FL-03 (8)	M12x1.5x45	120			
														Ø14	FL-04 (10)	M14x1.5x45	190	
																Ø16	FL-05 (12)	M16x1.5x50
225	60-220	150	50-125	196	140	15	4.5	5	168	171.4	B	Ø16	FL-03 (8)	M12x1.5x50	120			
														FL-05 (12)	M16x1.5x50	300		
250	70-250	170	50-130	218	140	18	5	7	186	190	B	Ø18	FL-03 (8)	M18x1.5x60	450			
285	80-280	180	60-150	245	175	20	5	7	210	214.5	B	Ø20	FL-03 (8)	M20x1.5x65	620			
														315	90-310	200	70-162	280
350	100-350	250	80-200	310	220	25	6	7	274	277.5	B	Ø22	FL-04 (10)	M22x1.5x75	830			
														390	120-440	300	90-230	345
435	140-550	350	100-260	385	280	32	7	7	343	338	B	Ø27	FL-04 (10)	M27x1.5x95	1600			

DIN Compact

Version A

Für Sechskantschrauben DIN 933-10.9
for hexagon bolts
DIN 933-10.9

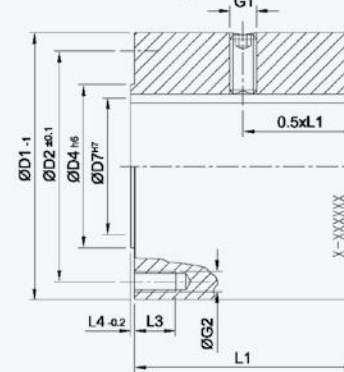

Version B

Gewindestift mit Innensechskant
Allen set screw
DIN 916

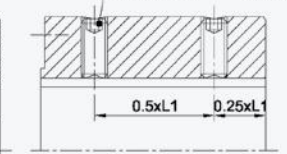

XXXXXX-X
ID Markierung einschließlich aller Kunden ID Daten
ID marking including all customer data

Material: C45

Alle Anschlussflansche einschließlich Gewindestifte
All companion flanges including Allen key screws

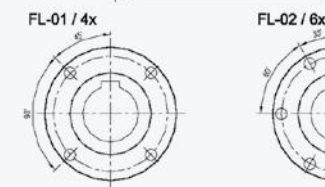

DIN Central

Für Sechskantschrauben DIN 933-10.9
for hexagon bolts
DIN 933-10.9

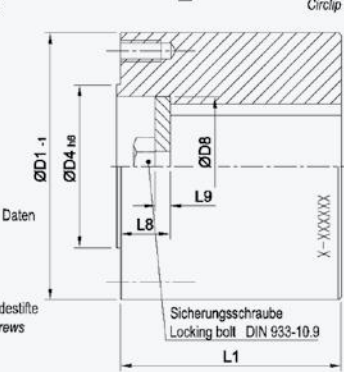

DIN Cap

Seegerring
Circlip
DIN 472

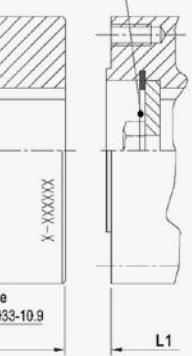

() = L1 Central + Cap Version * = meist gebrauchte Länge L1 most used length L1
** = Details Nabe + G1 siehe Seite 44-45 details sleeve + G1 see page 44-45

ØD1 mm	L1 mm	L1* mm	ØD7** mm	ØD2 mm	ØD4 mm	L3 mm	L4 mm	L8 mm	L9 mm	ØD8 mm	Ver sion	G2	Flansch flange	Schrauben bolts			
														Maß size	Mt Nm		
58	20-65 (35-65)	30	10-27	47	30	20	1.4	15	5	26	A	M5	FL-01 (4)	M5x15	9		
		50	28-37											B			
65	20-75 (35-75)	40	10-32	52	35	25	1.6	15	5	31	A	M6	FL-01 (4)	M6x20	14		
		55	33-40											B			
75	20-85 (35-85)	42	10-38	62	42	25	1.9	15	5	37	A	M6	FL-02 (6)	M6x20	14		
		60	39-50											B			
90	25-95 (45-95)	50	10-43	74.5	47	25	2.3	20	5	42	A	M8	FL-01 (4)	M8x20	35		
		75	44-60											B			
100	25-110 (45-110)	62	20-51	84	57	25	2.3	20	5	49	A	M8	FL-02 (6)	M8x20	35		
		80	52-68											B			
120	25-130 (45-130)	70	26-69	101.5	75	25	2.3	20	8	69	A	M8	FL-03 (8)	M8x20	35		
		100	70-82											B	M10x25	70	
150	35-170 (55-170)	100	41-82	130	90	25	2.8	20	8	82	A	M10	FL-03 (8)	M10x25	70		
		130	83-106											B	M12x25	120	
															M16x35	190	
180	50-205 (75-205)	120	41-100	155.5	110	30	2.8	25	10	99	B	M12	FL-03 (8)	M12x25	120		
		150	102-125											M14	FL-04 (10)	M14x35	190
225	60-250 (90-250)	150	50-130	196	140	35	4.5	30	12	128	B	M16	FL-03 (8)	M12x25	120		
			132-165											FL-05 (12)	M16x35	300	
250	70-285 (105-285)	170	50-130	218	140	35	5	35	15	128	B	M18	FL-03 (8)	M18x40	450		
		240	132-186											184			
285	80-320 (120-320)	180	60-165	245	175	45	5	40	20	160	B	M20	FL-03 (8)	M20x50	600		
		280	166-210											205			
315	90-350 (130-350)	200	70-165	280	175	45	5	40	30	160	B	M22	FL-03 (8)	M22x50	800		
		320	166-244											238			
350	100-390 (140-390)	250	80-200	310	220	45	6	40	30	198	B	M22	FL-04 (10)	M22x50	800		
		350	202-260											258			
390	120-440 (160-440)	300	90-230	345	250	50	6	50	40	226	B	M24	FL-04 (10)	M24x60	1000		
		400	232-300											296			
435	140-590 (180-590)	350	100-260	385	280	50	7	50	40	256	B	M27	FL-04 (10)	M27x70	1500		

Anschlussflansche

Companion flanges

SAE Standard Version A

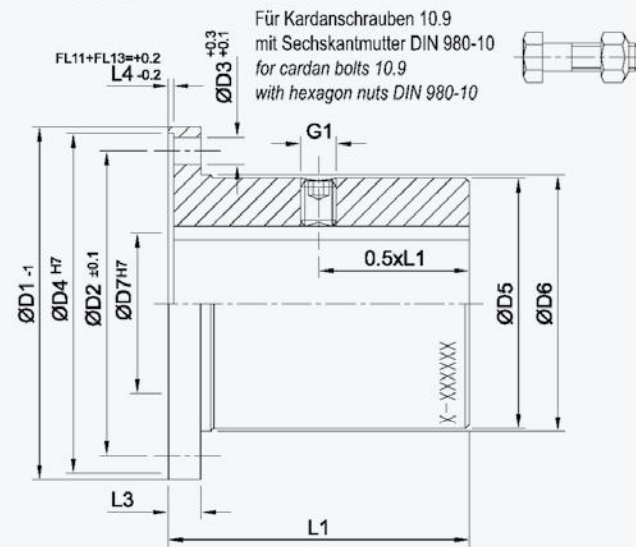

Version B

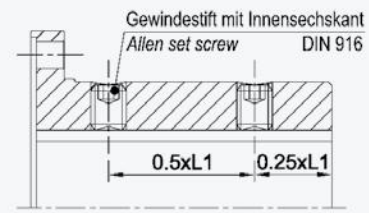

XXXXXX-X
ID Markierung einschließlich aller Kunden ID Daten
ID marking including all customer data

Material: C45

Alle Anschlussflansche einschließlich Gewindestifte
All companion flanges including Allen key screws

FL-11 / 4x
SAE 1120, 1300, 1400 und 1500

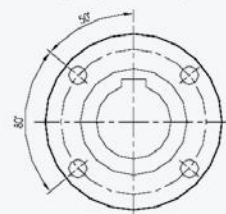

FL-12 / 8x
SAE 1600, 1700 und 1900

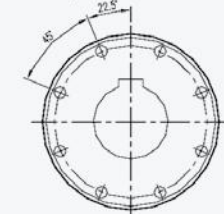

FL-13 / 8x
SAE 1880

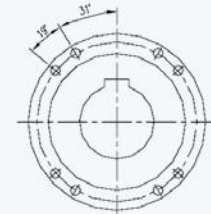

FL-14 / 12x
SAE 1800

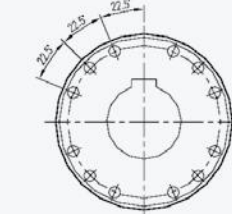

SAE Compact Version A

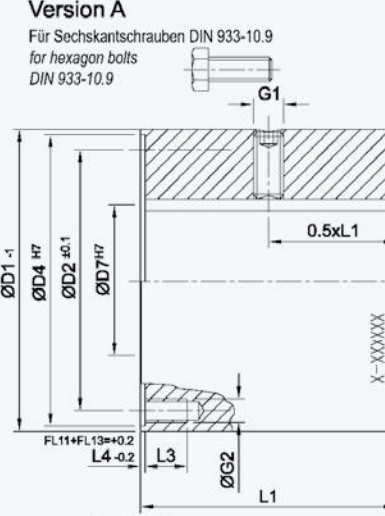

Version B

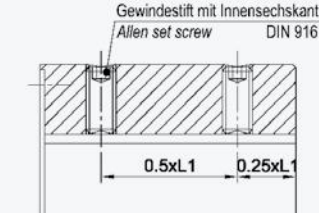

XXXXXX-X
ID Markierung einschließlich aller Kunden ID Daten
ID marking including all customer data

Material: C45

Alle Anschlussflansche einschließlich Gewindestifte
All companion flanges including Allen key screws

FL-11 / 4x
SAE 1120, 1300, 1400 und 1500

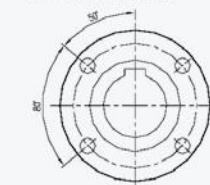

FL-12 / 8x
SAE 1600, 1700 und 1900

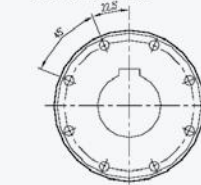

FL-13 / 8x
SAE 1880

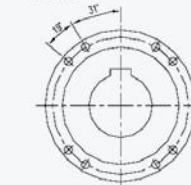

FL-14 / 12x
SAE 1800

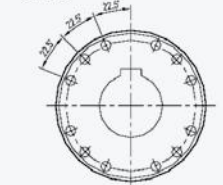

SAE Central

Für Sechskantschrauben DIN 933-10.9
for hexagon bolts
DIN 933-10.9

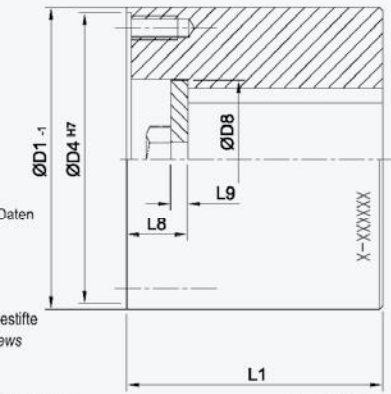

SAE Cap

Seegerring
Circlip DIN 472

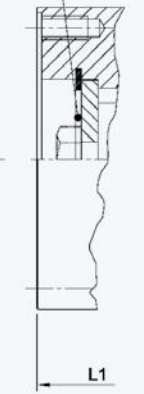

* = meist gebrauchte Länge L1 most used length L1

** = Details Nabe + G1 siehe Seite 44-45 details sleeve + G1 see page 44-45

() = L1 Central + Cap Version * = meist gebrauchte Länge L1 most used length L1

** = Details Nabe + G1 siehe Seite 45-46 details sleeve + G1 see page 45-46

ØD1 mm	L1 mm	L1* mm	ØD7** mm	ØD2 mm	ØD4 mm	L3 mm	L4 mm	L7 mm	ØD5 mm	ØD6 mm	Ver sion	ØD3 mm	Flansch flange	Schrauben bolts	
														Maß size	Mt Nm
90 1100	25-75	50	10-35	69.85	57.15	6	2	3	55	56.5	A	Ø8	FL-11 (4)	M8x1x25	36
		55	36-40											5/16"x1"	
96 1300	25-90	62	20-38	79.40	60.32	7	2	3	60	62	A	Ø10	FL-11 (4)	M10x1x30	70
		62	39-44											3/8"x1 3/16"	
116 1400	25-110	70	26-50	95.25	69.85	8	2	3	73	75.8	A	Ø12	FL-11 (4)	M12x1.5x40	120
		85	51-58											7/16"x1 5/8"	
150 1500	35-150	100	41-65	120.65	95.25	8	2	3	95	98.2	A	Ø14	FL-01 (4)	M14x1.5x45	190
		115	66-72											1/2"x1 3/4"	
175 1600	50-180	120	41-100	155.52	168.23	10	1.2	5	135	138	B	Ø10	FL-12 (8)	M10x1x30	70
														3/8"x1 3/16"	
203 1700 1800	60-220	150	50-130	184.15	196.82	11	1.2	5	165	166.7	B	Ø12	FL-12 (8)	M12x1.5x40	120
														7/16"x1 5/8"	
245 1880	70-250	170	50-150	209.55	177.8	15	1.2	5	182	185.2	B	Ø16	FL-13 (8)	M16x1.5x50	300
250 1900 GS	70-250	170	50-170	228.57	196.82	18	1.2	5	206	209	B	Ø12	FL-14 (12)	M12x1.5x50	120
														7/16"x1 5/8"	
276 1900	80-280	180	60-132	247.64 (251.70)	222.22	18	1.2	5	168	171.4	B	Ø16	FL-12 (8)	M16x1.5x60	300

ØD1 mm	L1 mm	L1* mm	ØD7** mm	ØD2 mm	ØD4 mm	L3 mm	L4 mm	L8 mm	L9 mm	ØD8 mm	Ver sion	G2 mm	Flansch flange	Schrauben bolts	
														Maß size	Mt Nm
90 1100	25-75 (45-75)	50	10-35	69.85	57.15	20	2	20	5	50	A	M8	FL-11 (4)	M8x20	35
		55	36-50											5/16"x 3/4"	
96 1300	25-90 (45-90)	62	20-38	79.40	60.32	25	2	20	5	62	A	M10	FL-11 (4)	M10x25	70
		62	39-54											3/8"x1"	
116 1400	25-110 (45-110)	70	26-50	95.25	69.85	25	2	20	8	75.8	A	M12	FL-11 (4)	M12x25	120
		85	51-64											7/16"x1"	
150 1500	35-150 (55-150)	100	41-65	120.65	95.25	35	2	20	8	98.2	A	M14	FL-01 (4)	M14x35	190
		115	66-88											1/2"x1 3/8"	
175 1600	50-180 (75-180)	120	41-140	155.52	168.23	25	1.2	25	10	138	B	M10	FL-12 (8)	M10x25	70
														3/8"x1"	
203 1700 1800	60-220 (85-220)	150	50-175	184.15	196.82	25	1.2	25	12	166.7	B	M12	FL-12 (8)	M12x25	120
														7/16"x1"	
245 1880	70-250 (105-250)	170	50-168	209.55	177.8	35	1.2	35	15	185.2	B	M16	FL-13 (8)	M16x35	300
250 1900 GS	70-250 (105-250)	170	50-186	228.57	196.82	25	1.2	35	15	209	B	M12	FL-14 (12)	M12x25	120
														7/16"x1"	
276 1900	80-280 (120-280)	180	60-190	247.64 (251.70)	222.22	35	1.2	40	20	171.4	B	M16	FL-12 (8)	M16x35	300

Anschlussflansche

Companion flanges

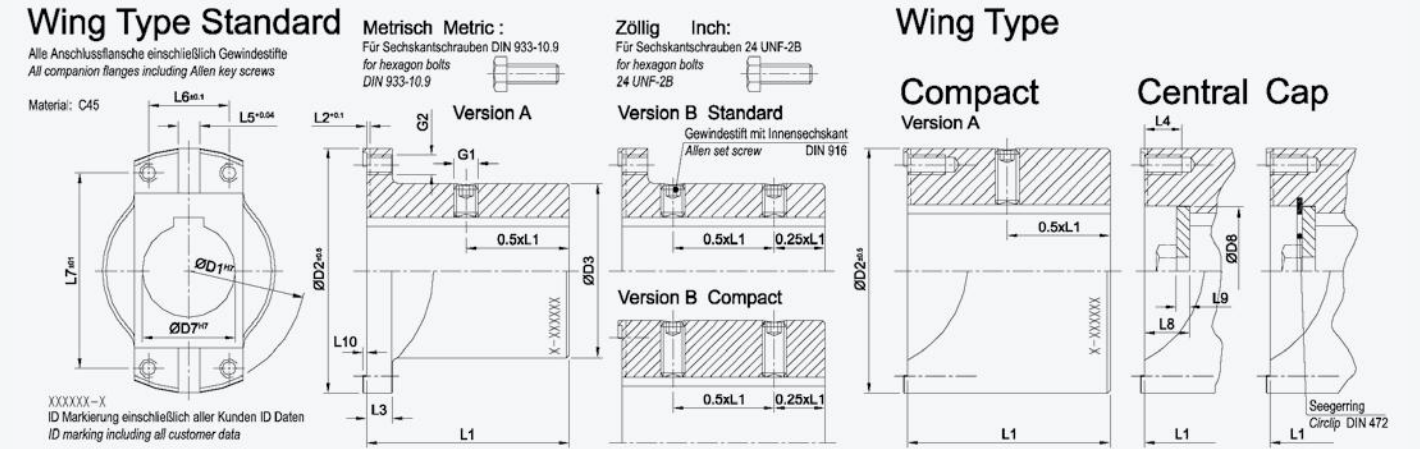
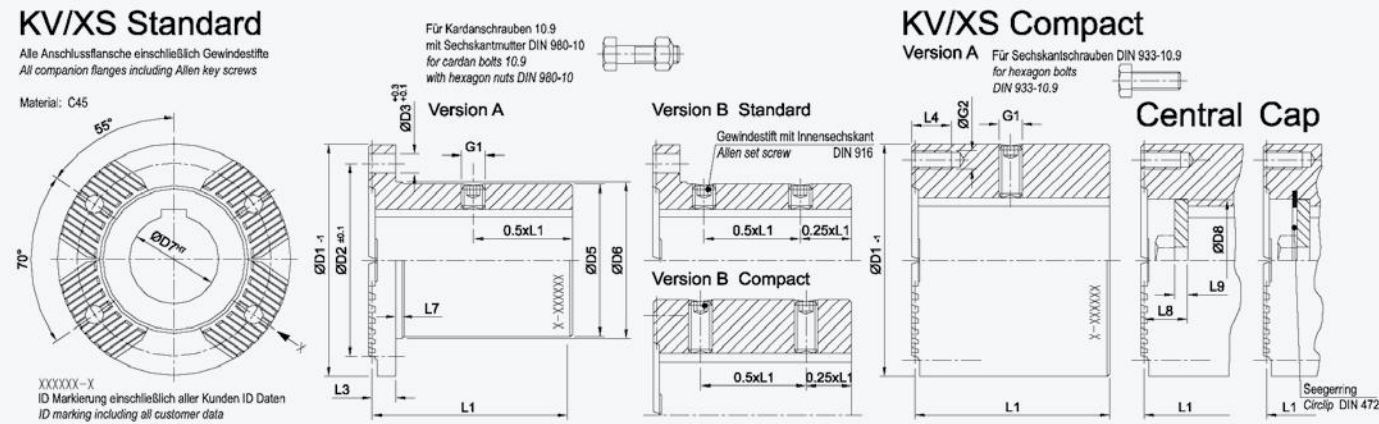

Ansicht X View X

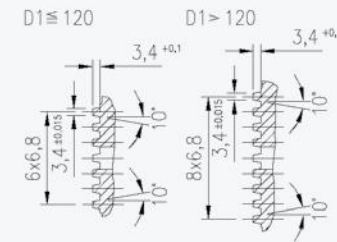

() = L1 Central + Cap Version * = meist gebrauchte Länge L1 most used length L1
 ** = Details Nabe + G1 siehe Seite 45-46 details sleeve + G1 see page 45-46

Flansch Maße flange size

Type	Mt max Nm	ØD1 mm	ØD2 mm	L2 mm	L3 mm	L4 mm	L5 mm	L6 mm	L7 mm	L10 mm	Schrauben bolts		
											G2 inch	G2 mm	Mt Nm
2C	800	79.35	85	3.8	9	25	9.5	33.32	59.53	2.8	5/16"x3/4" 24UNF-2B	M8x20	36
4C	1500	107.92	116	3.8	9	25	9.5	36.52	87.32	3.3	5/16"x1 1/8" 24UNF-2B	M8x40	36
5C	2600	115.06	123	5.1	11	25	14.26	42.9	88.9	4	3/8"x1 5/8" 24UNF-2B	M10x40	70
6C	3400	140.46	150	5.1	11	25	14.26	42.9	114.3	4	3/8"x1 5/8" 24UNF-2B	M10x40	70
7C	5700	148.38	158	5.9	13	30	15.85	49.2	117.5	4.8	1/2"x1 7/8" 20UNF-2B	M12x50	120
8C	8500	206.32	216	5.9	13	30	15.85	49.2	174.6	4.8	1/2"x1 7/8" 20UNF-2B	M12x50	120
8.5C	14000	165.07	175	5.9	15	30	15.85	71.42	123.8	4.8	1/2"x2" 20UNF-2B	M12x60	120
9C	18000	209.52	223	5.9	15	30	15.85	71.42	168.28	4.8	1/2"x2" 20UNF-2B	M12x60	120

Größere Flansche bis 15C auf Anfrage larger flanges up to 15C on request

ØD1 mm	L1 mm	L1* mm	ØD7** mm	ØD2 mm	ØD3 mm	L3 mm	L4 mm	L7 mm	L8 mm	L9 mm	ØD5 mm	ØD6 mm	ØD8 mm	Ver sion	G2 mm	Schrauben bolts	
																Maß size	Mt Nm
100	25-110 (45-110)	62	20-40	84	Ø8	10	20	3	20	5	69	70.8	49	A	M8	M8x1x30	36
		80	41-50 (41-60)													M8x20	
120	25-130 (45-130)	70	26-50	100	Ø11	14	25	5	20	8	82	84.1	69	A	M10	M10x1x40	70
		100	51-60 (61-70)													M10x25	
150	35-170 (55-170)	100	41-70	130	Ø13	16	25	5	20	8	108	110.6	82	A	M12	M12x1.5x45	120
		130	71-80 (71-100)													M12x25	
180	50-205 (75-205)	120	41-90	150	Ø15	18	35	5	25	10	125	127.5	99	A	M14	M14x1.5x55	190
		150	41-120													M14x35	
200	60-250 (90-250)	150	50-100	165	Ø15	20	35	5	30	12	140	142.5	119	B	M14	M14x1.5x55	190
			50-130													M14x35	

Anschlussflansch Maße companion flansch size

() = L1 Central + Cap Version * = meist gebrauchte Länge L1 most used length L1
 ** = Details Nabe + G1 siehe Seite 45-46 details sleeve + G1 see page 46-46

Type	Mt max Nm	ØD7 mm	ØD3 mm	Standard+Compact		Central+Cap		Central+Cap		
				L1 mm	L1* mm	L1 mm	L1* mm	L8 mm	L9 mm	ØD8 mm
2C	800	10-30	50	25-75	50	40-90	65	15	5	40
4C	1500	20-55	75	25-90	60	45-110	80	20	5	60
5C	2600	20-55	75	25-90	60	45-110	80	20	8	60
6C	3400	30-70	100	35-150	110	55-170	130	20	8	80
7C	5700	30-70	100	35-150	110	55-170	130	20	8	80
8C	8500	40-110	150	50-200	140	65-225	165	25	10	120
8.5C	14000	30-70	100	35-150	110	55-170	130	25	10	80
9C	18000	40-110	150	50-200	140	65-225	165	25	10	120

Größere Anschlussflansche bis 15C auf Anfrage larger companion flanges up to 15C on request